





CERTA RANGE SMALL-BUSINESS

The small business category locks provide perfect mechanical security combined with the best features of motor locks. These locks are ideal choice for high-traffic doors, where access control is required, but indication information or door automatics are not necessary. The locks can always be opened by inside handle. Mechanical opening by cylinder is also always possible.

SINGLE POINT LOCK CASES

EL418, EL518



RECOMMENDED PRODUCTS

				
EA324	EA221	EA281	CY323T	DH004/ 040 Ms/Cr

INDICATIONS



STANDARD APPROVALS



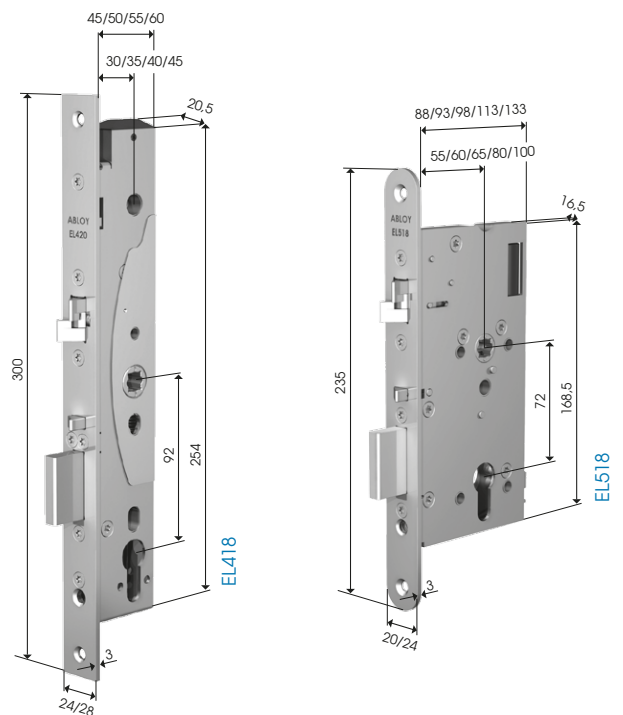

 



MULTIPOINT LOCK CASES

MP418, MP518

RECOMMENDED PRODUCTS

				
EA324/ EA306	EA221	EA281	CY323T	DH004/ 040 Ms/Cr

INDICATIONS



STANDARD APPROVALS

