

# Code**GUARD**5™



## Access control made secure

Secured by Design



Police Preferred Specification



BS8607:2014  
+A1: 2016  
Lic. KM 690973

**UNION**

**ASSA ABLOY**

Trusted by **Professionals**

Experience a safer  
and more open world

# From our first lock made in 1840, UNION's expertise is second to none.

Exceptional quality. Engineered with precision. Durable in the most demanding environments. You'll find UNION hardware fitted to doors across the world. From commercial to residential buildings, educational to healthcare, people and businesses rely on UNION for safety and security.

Now UNION brings legendary levels of quality, and durability to push button locks solutions with **CodeGUARD 5™** - the first access control device that meets the tough BS8607 Grade 5 award.

The only Secured by Design approved pushbutton lock. The **CodeGUARD 5™** offers real security that truly protects people and assets. Designed from the ground up to be the toughest pushbutton lock, going far beyond the limits of lesser devices.

**CodeGUARD 5™** is the new leader in mechanical access control, so tough it wears the renowned BSI Kite Mark. No other device comes close.

**Make the professional choice. Make it UNION.**



**FIT AND FORGET.**



# Serious Access Control

**CodeGUARD 5** from UNION is a new generation of push button mechanical locks, purpose-designed to combine both high security and access control.

Tested to the limits of endurance. 200,000 relentless test cycles to make sure the latch works first time, every time. Prolonged exposure to corrosive salt water, making sure the 304 grade Stainless Steel construction keeps your door secure in the harshest conditions.

And continual, brutal assault to make sure you install a push button lock solution that delivers what you really want – reliable security that exceeds BS8607.

The result? A push button lock which you can install almost anywhere and will protect you from violent attack, shrugging off abuse thanks to its fortress construction and integrated deadlocking latch that makes it much stronger than lesser alternatives.



**CodeGUARD 5** reaches new performance levels never seen before. That's why BSI awarded **CodeGUARD 5** the new BS8607 Grade 5, the highest grade possible. Only devices that make this grade can use the coveted BSI Kite Mark. And with a 3 year guarantee as standard, you can safely recommend **CodeGUARD 5** with the confidence to Fit and Forget.



# BS8607: What You Need To Know

BS8607 provides a way to classify Mechanically Operated Push Button Locksets (PBL). These products are generally used for access control, but they are also found on fire doors and perimeter doors. The standard gives guidance to specifiers of the performance of these types of product.

**Grade 5 Mechanically Operated Push Button Locksets** have a high level of security against attack. A Grade 5 PBL will have successfully passed a General Vulnerability Assessment (GVA) meaning it has been attacked using tools such as HSS drill bits, vice grips, cordless drills, picking tools, chisels and wedges etc.

**A Grade 5 PBL** will feature automatic locking with keyless egress using a built-in locking unit.

**A Grade 5 PBL** can therefore be considered for perimeter doors around a building. Products tested to Grade 5 will have a security level equivalent to BS3621:2017 for thief resistant lock assemblies and are permitted to display a British Standard Kite Mark with the relevant standard code.



- 

**Device Security Meets BS3621: 2017**  
Bringing security to access control, a push button lock must pass the stringent tests under BS3621:2017
- 

**Integral, Built-In Security Bolt**  
Grade 5 Push Button Locks have a security bolt built into the unit to keep a door secure
- 

**Automatic Locking Via Integrated Locking Device**  
Only Grade 5 Push Button Locks have an integrated lock, automatically locking a door after use
- 

**Keyless Egress**  
One product provides protection and the convenience of access control without the need for wiring
- 

**Displays BSI Kite Mark**  
The BS Kite Mark can only be displayed on a push button lock meeting Grade 5

## Application Grades

A Mechanical Push-button Lockset is designated as Grade 1, 2, 3, 4 or 5 according to the following intended applications:

<b>Grade 1</b>	Internal applications where users have a high incentive to exercise care and where the expected usage is low
<b>Grade 2</b>	Internal applications where users have little incentive to exercise care and where the expected usage is high
<b>Grade 3</b>	Applications where abuse and usage levels are expected to be high and there is an element of security
<b>Grade 4</b>	Applications where security, abuse and usage levels are expected to be equivalent to BS 3621:2017, but which can only be achieved with the help of an integral additional locking unit (additional security bolt). The optional locking arrangement cannot be separated from the mechanical operated push-button lock without dismantling
<b>Grade 5</b>	Applications where security, abuse and usage levels are expected to be equivalent to BS 3621:2017 and locking is automatic via an integrated lock with keyless egress, with the display of a British Standards Kite Mark as demonstration of performing to this standard

# CodeGUARD 5. Access Control With Security As Standard

Not all Push Button Locks are created equal. **CodeGUARD 5** contains unmatched strength and durability - designed and tested to protect against serious sustained attack.

Take a look round **CodeGUARD 5** and discover its hidden strengths.

## Universal applications

Universal handing and fixings for timber and metal doors – easy to order and simple to specify. One product suits all applications



## Contemporary aesthetics

Ergonomic styled handles and attractive finish. A push button lock that complements modern décor



## Personalised factory code

Each product is issued with its own individual code to deter opportunists if the factory code is not reset



## Secure

Over 2000 combinations available to ward off even determined random code guessing



## Secure bolt-through fixings

Resistance to sustained attack when trying to remove the unit from the door



 **FIT AND FORGET.**

## Secured by Design

Tested and approved ensuring security and peace of mind



## Access control and security - no compromise.

One product provides protection and the convenience of access control without the need for wiring



## High corrosion resistance

Ideal for perimeter security applications. Maintains aesthetics and performance over time



## Suitable for fire doors

30 and 60 minute timber fire doors and 240 minute metal fire doors



## Reliable

3 Year guarantee – Reassuring quality and reliability that you would expect from UNION



Only Grade 5 push button locks can use the BSI Kite Mark



BS8607:2014  
+A1: 2016  
Lic.KM 690973

## Auto firing pin

An extra line of security, if the unit is removed from the door, the auto firing pin releases to deadlock the unit permanently preventing manipulation of spindle



## Robust design

The deadlocking latch construction provides increased resistance to attack

## 20mm deadlocking latch

High resistance to attack. Protecting people, data and your assets



## Security strike box

Protects against end load and side load attack, tested to withstand a constant force of 10KN/m

## Auxillary latch

Automatically deadlocks the latch when it comes into contact with the security box strike

## Fully tested to BS8607:2014+A1:2016

- Kite Marked to Grade 5 – Licence No 690973
- CodeGUARD 5 has been successfully fire tested to BS EN 1634-1: 2014
- Suitable for 30 and 60 minute timber fire doors  
Note: if installing CodeGUARD on timber fire doors please use the approved intumescent kit J8607CG5-1K
- Suitable for 240 minute metal fire doors
- Fully tested to (latch only) EN12209:2003 classification code 2|M|4|1|0|F|6|B|H|1|0

## Stadia

In just minutes a stadium can transform from empty to holding thousands of people, making effective security within an access control policy a major issue. **CodeGUARD 5** provides high security for zones where only authorised personnel are permitted.



## Sensitive Data

Protecting data in line with GDPR requirements has never been greater. Paper and digital files can be at risk of theft - both by intruders or internal staff. And, as few storage or server rooms are continually patrolled, **CodeGUARD 5** is ideal for physical protection of assets, keeping your information safe and avoiding GDPR breaches.

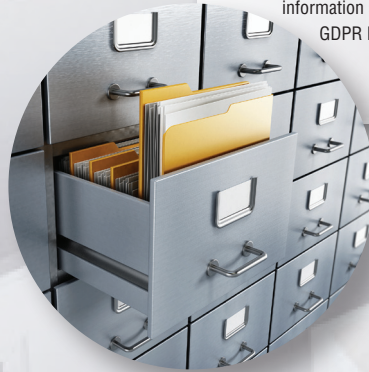

## Retail and Consumer Goods

**CodeGUARD 5** brings instant security to doors to retailer cash rooms and deters break-ins from opportunistic thieves into store rooms. Perfect for securing high value stock such as computers, mobile phones, watches and jewellery.



## Public Buildings

Ownership, management and use of public buildings has evolved over recent years, making security for staff, assets and users difficult to achieve. **CodeGuard 5** is the ideal retro-fit to existing buildings, improving security and complimenting existing systems.



# To Access Control - Everywhere

## Pharmaceuticals & Chemicals

Controlled substances - from medicines to toxic chemicals - can be difficult to keep secure across facilities. Using **CodeGUARD 5** reduces theft, keeping the door firmly in place and preventing the dangerous misuse of chemicals and prescription drugs.



## Transport Security

**CodeGUARD 5**'s combination of high security and access control restricts entry to zones within transport hubs and terminals, helping to protect staff as they work and travellers as they journey on planes, ships and trains.



## Health

Health facilities containing valuable medicines and equipment are vulnerable to theft. **CodeGUARD 5** provides a barrier against even determined break-in attempts, safeguarding medical equipment, data, and of course vulnerable patients and staff.



## Civil Defence and Emergency Services

Police, Fire and Health services often need to store potentially dangerous items – and access restricted areas fast. The robust design of **CodeGUARD 5** not only thwarts a determined assault, it also shrugs off heavy use by staff as they rush to undertake their work under pressure.



## Education

Using **CodeGUARD 5** undoubtedly protects the safety of pupils and the members of staff within a building. Important files, information and expensive equipment can be stored away securely with **CodeGUARD 5** preventing unauthorised access and forced entry.



# CodeGUARD 5 Dimensions

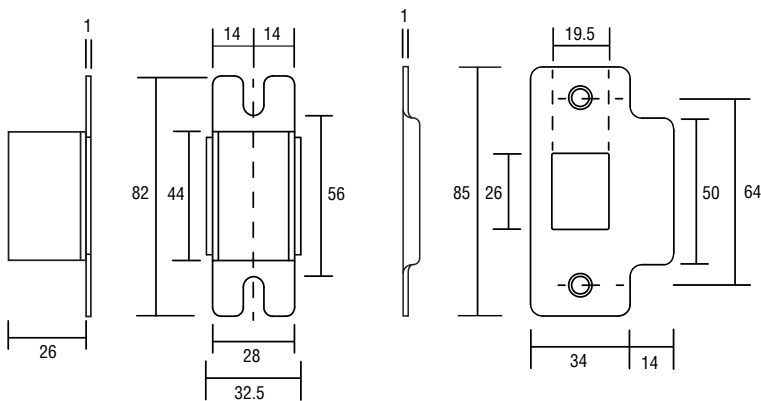
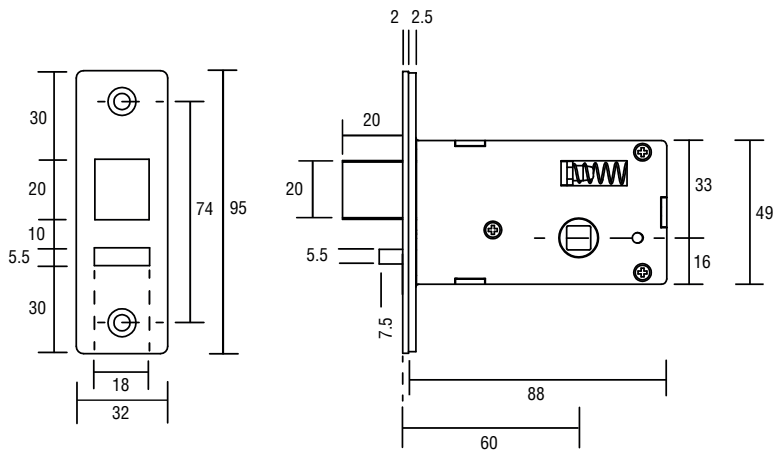
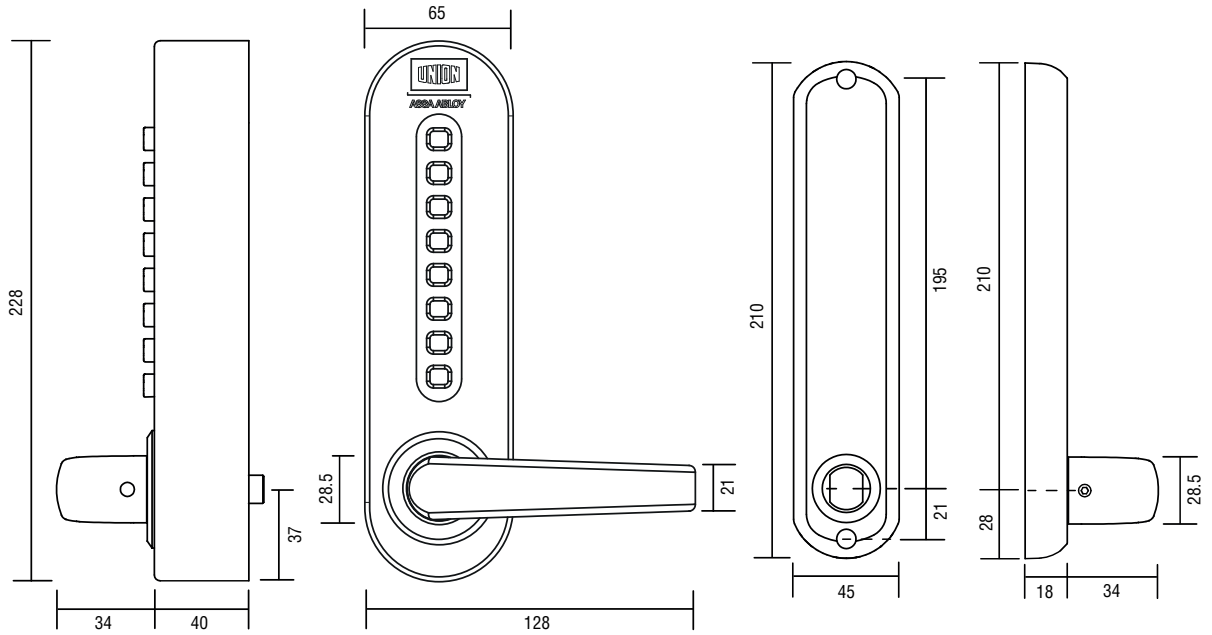

# UNION - We're All About The Door

## Door closers

UNION door closers play an essential part in access control. They are suitable for timber and metal fire doors for almost any application and environment, all subject to the most rigorous fire tests to meet the EN 1154 or EN 1155 standards.

## Signage

Clear and simple signage made to last using stainless steel and the industry standard blue and font sizing.

## Levers & Handles

Now you can fit handles to fire doors which not only meet BS EN 1634 - but look great too!

## Hinges

Supporting doors up to 120Kg, UNION hinges are suitable for heavy duty applications and on doors used frequently without incentive to exercise care.

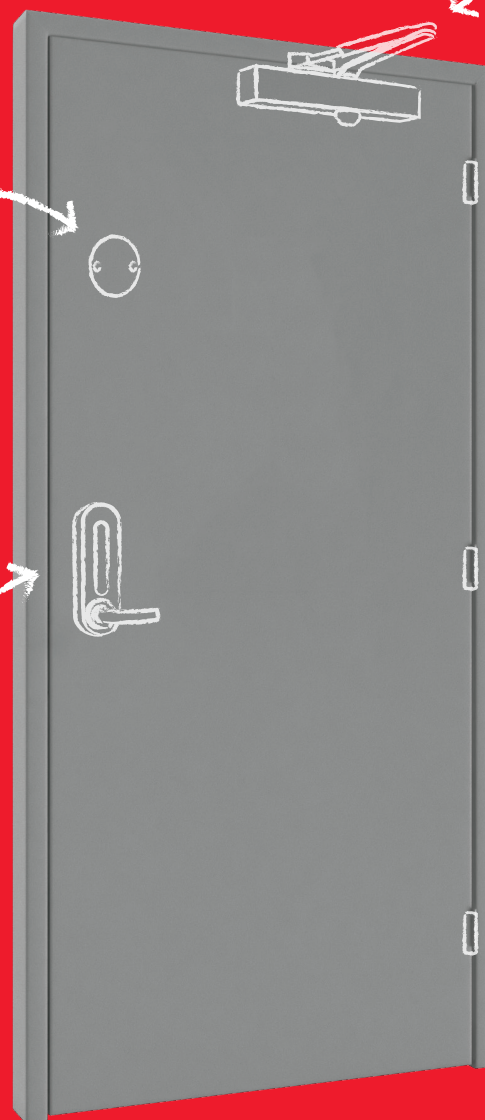

## Door hold open solutions

DoorSense is a standalone unit that can be fixed in seconds that lets you keep a fire door open - and have it close if the alarm sounds, or at a set time. These are not suitable for use on doors where access control is required at all times.

The ASSA ABLOY Group is the global leader in access solutions. Every day we help people feel safe, secure and experience a more open world.

**ASSA ABLOY**

ASSA ABLOY Opening Solutions UK & Ireland  
Door Hardware Group  
School Street, Willenhall  
WV13 3PW  
UK Tel: 0845 223 2124  
Email: [csdcomm@assaabloy.com](mailto:csdcomm@assaabloy.com)  
Web: [www.uniononline.co.uk](http://www.uniononline.co.uk)

Version 2.0 - Feb 2020